



REVISION HISTORY

<u>Revision</u>	<u>Description</u>	<u>Issue Date</u>
Rev. 1.0.	Initial Issue	Jul.25.2004
Rev. 2.0.	Revised Vcc Range(Vcc=4.5~5.5V => 2.7~5.5V)	May.4.2005
Rev. 2.1.	Revised I _{SB1}	May.13.2005
Rev. 2.2	Adding PKG type : skinny P-DIP	Aug.29.2005
Rev. 2.3	Revised V _{IH} (min)=2.4V, V _{IL} (max)=0.6V	Feb.24.2006
Rev. 2.4	Revised V _{IH} (min)=2.4V, V _{IL} (max)=0.6V (V _{CC} =2.7~3.6V) V _{IH} (min)=2.4V, V _{IL} (max)=0.8V (V _{CC} =4.5~5.5V)	Jul.31.2006
Rev. 2.5	Revised STSOP Package Outline Dimension	Mar.26.2008

FEATURES

- Fast access time : 35/55/70ns
- Low power consumption:
Operating current : 20/15/10mA (TYP.)
Standby current : 1 μ A (TYP.) LL-version
- Single 2.7~5.5V power supply
- All inputs and outputs TTL compatible
- Fully static operation
- Tri-state output
- Data retention voltage : 1.5V (MIN.)
- **Lead free and green package available**
- Package : 28-pin 600 mil PDIP
28-pin 330 mil SOP
28-pin 8mm x 13.4mm STSOP
28-pin 300 mil Skinny P-DIP

GENERAL DESCRIPTION

The LY62256 is a 262,144-bit low power CMOS static random access memory organized as 32,768 words by 8 bits. It is fabricated using very high performance, high reliability CMOS technology. Its standby current is stable within the range of operating temperature.

The LY62256 is well designed for low power application, and particularly well suited for battery back-up nonvolatile memory application.

The LY62256 operates from a single power supply of 2.7~5.5V and all inputs and outputs are fully TTL compatible

PRODUCT FAMILY

Product Family	Operating Temperature	Vcc Range	Speed	Power Dissipation	
				Standby(I _{SB1} ,TYP.)	Operating(I _{CC} ,TYP.)
LY62256	0 ~ 70°C	2.7 ~ 5.5V	35/55/70ns	1 μ A(LL)	20/15/10mA
LY62256(E)	-20 ~ 80°C	2.7 ~ 5.5V	35/55/70ns	1 μ A(LL)	20/15/10mA
LY62256(I)	-40 ~ 85°C	2.7 ~ 5.5V	35/55/70ns	1 μ A(LL)	20/15/10mA

FUNCTIONAL BLOCK DIAGRAM

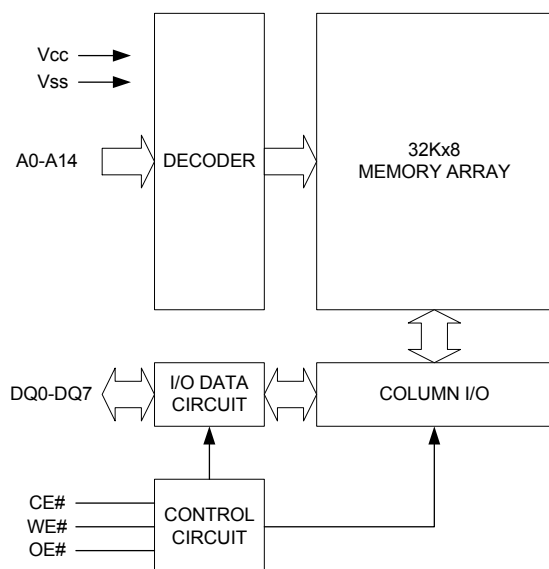

PIN DESCRIPTION

SYMBOL	DESCRIPTION
A0 - A14	Address Inputs
DQ0 - DQ7	Data Inputs/Outputs
CE#	Chip Enable Input
WE#	Write Enable Input
OE#	Output Enable Input
Vcc	Power Supply
Vss	Ground

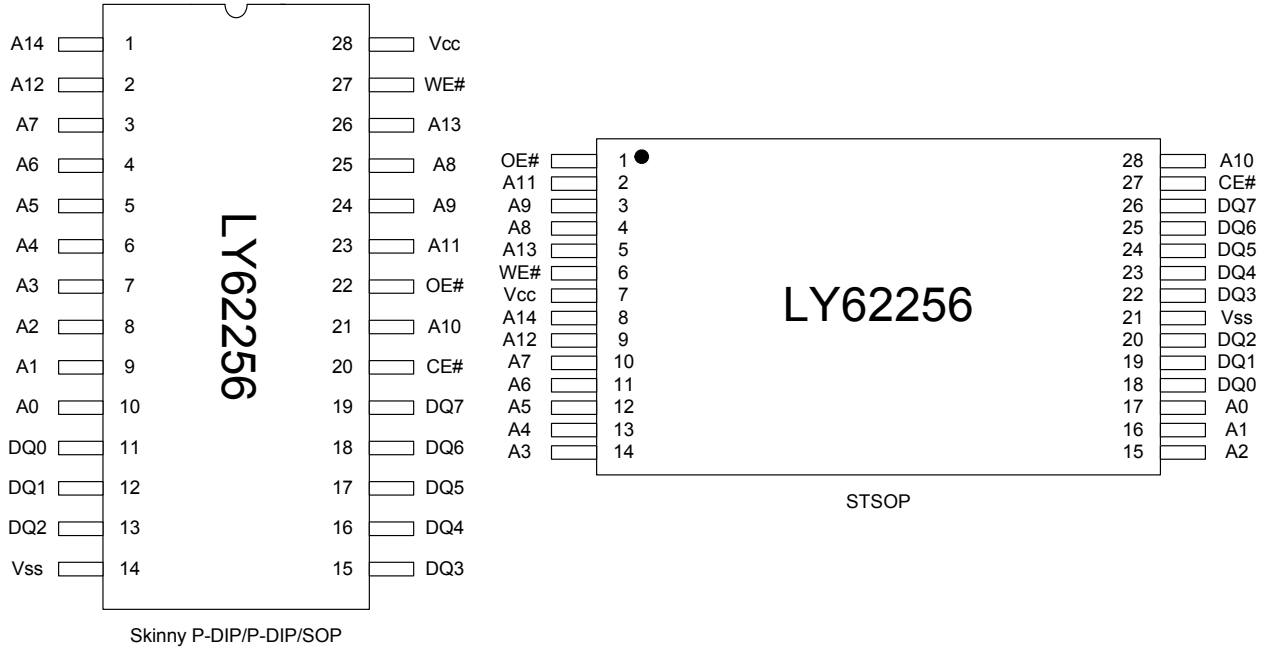
PIN CONFIGURATION

ABSOLUTE MAXIMUM RATINGS*

PARAMETER	SYMBOL	RATING	UNIT
Terminal Voltage with Respect to V _{SS}	V _{TERM}	-0.5 to 7.0	V
Operating Temperature	T _A	0 to 70(C grade)	°C
		-20 to 80(E grade)	
		-40 to 85(I grade)	
Storage Temperature	T _{STG}	-65 to 150	°C
Power Dissipation	P _D	1	W
DC Output Current	I _{OUT}	50	mA
Soldering Temperature (under 10 sec)	T _{SOLDER}	260	°C

*Stresses greater than those listed under "Absolute Maximum Ratings" may cause permanent damage to the device. This is a stress rating only and functional operation of the device or any other conditions above those indicated in the operational sections of this specification is not implied. Exposure to the absolute maximum rating conditions for extended period may affect device reliability.

TRUTH TABLE

MODE	CE#	OE#	WE#	I/O OPERATION	SUPPLY CURRENT
Standby	H	X	X	High-Z	I _{SB} , I _{SB1}
Output Disable	L	H	H	High-Z	I _{CC} , I _{CC1}
Read	L	L	H	D _{OUT}	I _{CC} , I _{CC1}
Write	L	X	L	D _{IN}	I _{CC} , I _{CC1}

Note: H = V_{IH}, L = V_{IL}, X = Don't care.



DC ELECTRICAL CHARACTERISTICS

PARAMETER	SYMBOL	TEST CONDITION	MIN.	TYP. ⁵	MAX.	UNIT
Supply Voltage	V _{CC}		2.7	3.3	5.5	V
Input High Voltage	V _{IH} ¹		2.4	-	V _{CC} +0.5	V
Input Low Voltage	V _{IL} ²	V _{CC} =2.7~3.6V	-0.5	-	0.6	V
		V _{CC} =4.5~5.5V	-0.5	-	0.8	V
Input Leakage Current	I _{LI}	V _{CC} ≥ V _{IN} ≥ V _{SS}	-1	-	1	μA
Output Leakage Current	I _{LO}	V _{CC} ≥ V _{OUT} ≥ V _{SS} , Output Disabled	-1	-	1	μA
Output High Voltage	V _{OH}	I _{OH} = -1mA	2.4	3.0	-	V
Output Low Voltage	V _{OL}	I _{OL} = 2mA	-	-	0.4	V
Average Operating Power supply Current	I _{CC}	Cycle time = Min. CE# = V _{IL} , I _{I/O} = 0mA	-35	20	50	mA
			-55	15	45	mA
			-70	10	40	mA
	I _{CC1}	Cycle time = 1μs CE# ≤ 0.2V and I _{I/O} = 0mA other pins at 0.2V or V _{CC} -0.2V	-	3	10	mA
Standby Power Supply Current	I _{SB}	CE# = V _{IH}	-	1	3	mA
	I _{SB1}	CE# ≥ V _{CC} - 0.2V	V _{CC} =2.7~3.6V	1	20 ^{4*6}	μA
			V _{CC} =2.7~5.5V	1	50 ⁴	μA

Notes:

- V_{IH}(max) = V_{CC} + 3.0V for pulse width less than 10ns.
- V_{IL}(min) = V_{SS} - 3.0V for pulse width less than 10ns.
- Over/Undershoot specifications are characterized, not 100% tested.
- 10μA for special request
- Typical values are included for reference only and are not guaranteed or tested.
Typical valued are measured at V_{CC} = V_{CC}(TYP.) and T_A = 25°C
- This value is measured at V_{CC} = 3.6V.

CAPACITANCE (T_A = 25°C, f = 1.0MHz)

PARAMETER	SYMBOL	MIN.	MAX	UNIT
Input Capacitance	C _{IN}	-	6	pF
Input/Output Capacitance	C _{I/O}	-	8	pF

Note : These parameters are guaranteed by device characterization, but not production tested.

AC TEST CONDITIONS

Input Pulse Levels	0.2V to V _{CC} - 0.2V
Input Rise and Fall Times	3ns
Input and Output Timing Reference Levels	1.5V
Output Load	C _L = 50pF + 1TTL, I _{OH} /I _{OL} = -1mA/2mA



AC ELECTRICAL CHARACTERISTICS

(1) READ CYCLE

PARAMETER	SYM.	LY62256-35		LY62256-55		LY62256-70		UNIT
		MIN.	MAX.	MIN.	MAX.	MIN.	MAX.	
Read Cycle Time	t _{RC}	35	-	55	-	70	-	ns
Address Access Time	t _{AA}	-	35	-	55	-	70	ns
Chip Enable Access Time	t _{ACE}	-	35	-	55	-	70	ns
Output Enable Access Time	t _{OE}	-	25	-	30	-	35	ns
Chip Enable to Output in Low-Z	t _{CLZ} *	10	-	10	-	10	-	ns
Output Enable to Output in Low-Z	t _{OLZ} *	5	-	5	-	5	-	ns
Chip Disable to Output in High-Z	t _{CHZ} *	-	15	-	20	-	25	ns
Output Disable to Output in High-Z	t _{OHZ} *	-	15	-	20	-	25	ns
Output Hold from Address Change	t _{OH}	10	-	10	-	10	-	ns

(2) WRITE CYCLE

PARAMETER	SYM.	LY62256-35		LY62256-55		LY62256-70		UNIT
		MIN.	MAX.	MIN.	MAX.	MIN.	MAX.	
Write Cycle Time	t _{WC}	35	-	55	-	70	-	ns
Address Valid to End of Write	t _{AW}	30	-	50	-	60	-	ns
Chip Enable to End of Write	t _{CW}	30	-	50	-	60	-	ns
Address Set-up Time	t _{AS}	0	-	0	-	0	-	ns
Write Pulse Width	t _{WP}	25	-	45	-	55	-	ns
Write Recovery Time	t _{WR}	0	-	0	-	0	-	ns
Data to Write Time Overlap	t _{DW}	20	-	25	-	30	-	ns
Data Hold from End of Write Time	t _{DH}	0	-	0	-	0	-	ns
Output Active from End of Write	t _{OW} *	5	-	5	-	5	-	ns
Write to Output in High-Z	t _{WHZ} *	-	15	-	20	-	25	ns

*These parameters are guaranteed by device characterization, but not production tested.

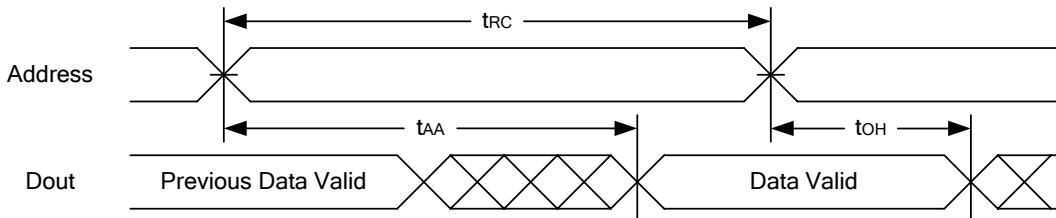
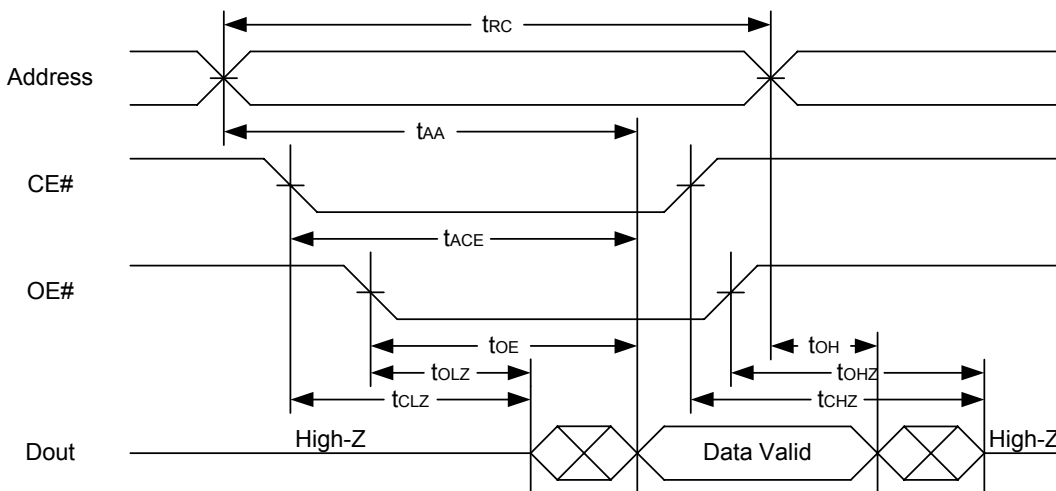
TIMING WAVEFORMS
READ CYCLE 1 (Address Controlled) (1,2)

READ CYCLE 2 (CE# and OE# Controlled) (1,3,4,5)

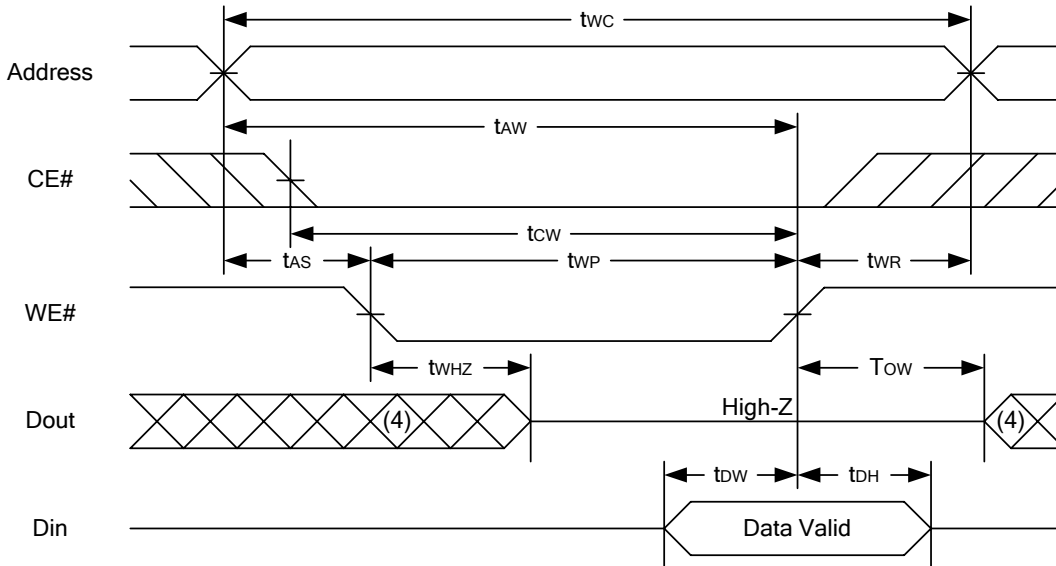
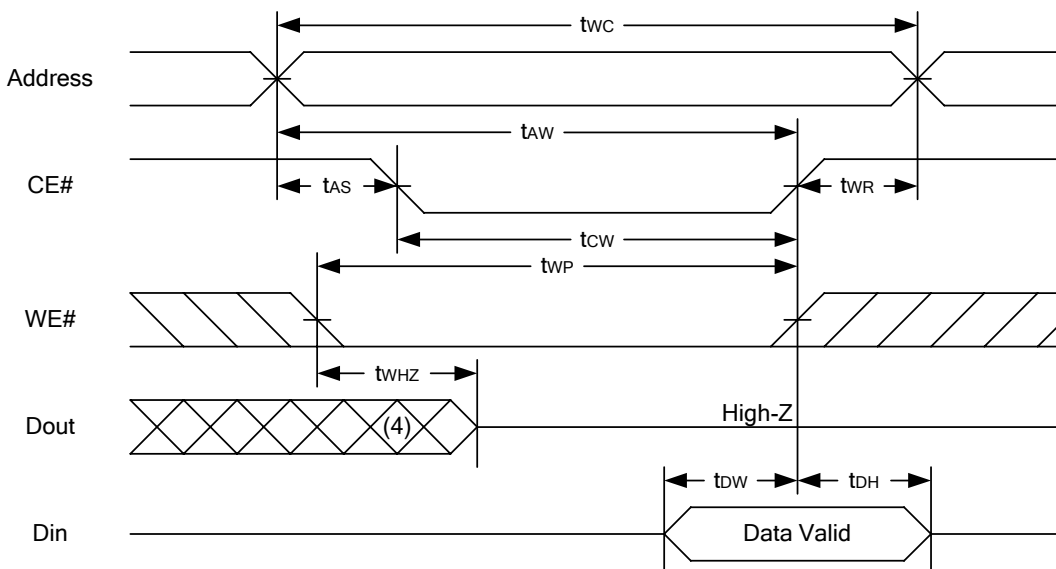
Notes :

1. WE# is high for read cycle.
2. Device is continuously selected OE# = low, CE# = low.
3. Address must be valid prior to or coincident with CE# = low; otherwise t_{AA} is the limiting parameter.
4. t_{CLZ} , t_{OLZ} , t_{CHZ} and t_{OHZ} are specified with $C_L = 5\text{pF}$. Transition is measured $\pm 500\text{mV}$ from steady state.
5. At any given temperature and voltage condition, t_{CHZ} is less than t_{CLZ} , t_{OHZ} is less than t_{OLZ} .

WRITE CYCLE 1 (WE# Controlled) (1,2,3,5,6)

WRITE CYCLE 2 (CE# Controlled) (1,2,5,6)

Notes :

1. WE#, CE# must be high during all address transitions.
2. A write occurs during the overlap of a low CE#, low WE#.
3. During a WE# controlled write cycle with OE# low, t_{wp} must be greater than $t_{whz} + t_{dw}$ to allow the drivers to turn off and data to be placed on the bus.
4. During this period, I/O pins are in the output state, and input signals must not be applied.
5. If the CE# low transition occurs simultaneously with or after WE# low transition, the outputs remain in a high impedance state.
6. t_{ow} and t_{whz} are specified with $C_L = 5pF$. Transition is measured $\pm 500mV$ from steady state.



DATA RETENTION CHARACTERISTICS

PARAMETER	SYMBOL	TEST CONDITION	MIN.	TYP.	MAX.	UNIT
V _{CC} for Data Retention	V _{DR}	CE# \geq V _{CC} - 0.2V	1.5	-	5.5	V
Data Retention Current	I _{DR}	V _{CC} = 2.0V CE# \geq V _{CC} - 0.2V	-	0.5	20	μ A
Chip Disable to Data Retention Time	t _{CDR}	See Data Retention Waveforms (below)	0	-	-	ns
Recovery Time	t _R		t _{RC*}	-	-	ns

t_{RC*} = Read Cycle Time

DATA RETENTION WAVEFORM

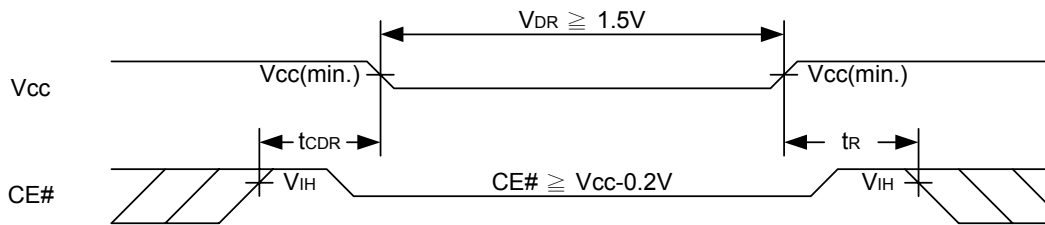

PACKAGE OUTLINE DIMENSION

28 pin 600 mil PDIP Package Outline Dimension

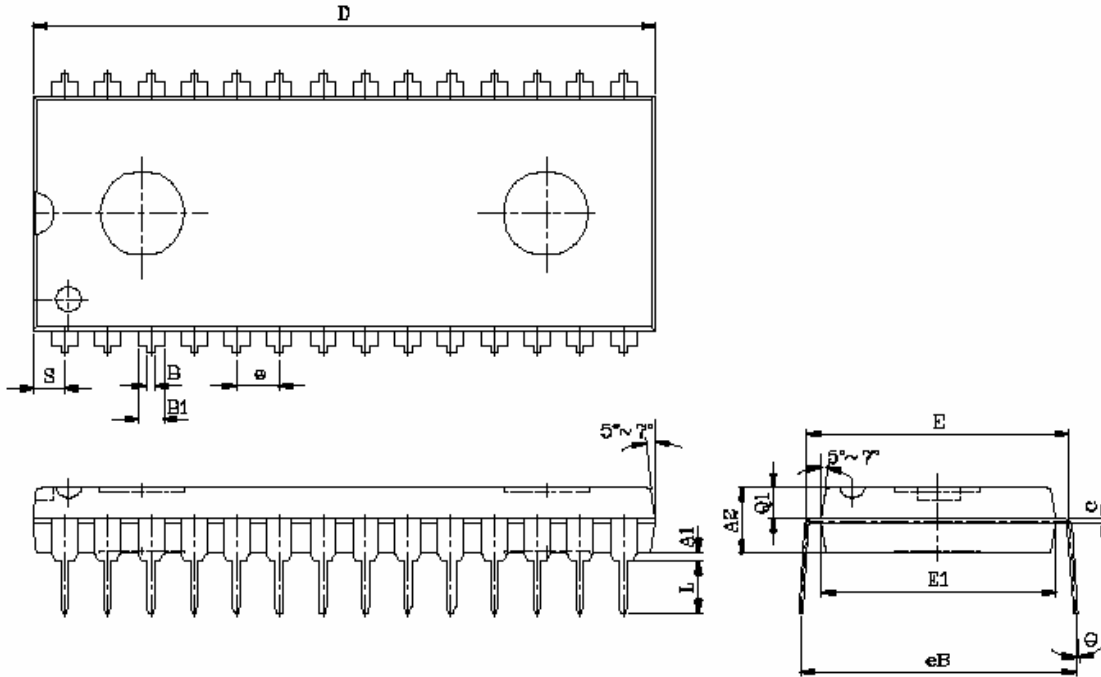

SYM.	UNIT	INCH.(BASE)	MM(REF)
A1		0.010 (MIN)	0.254 (MIN)
A2		0.150±0.005	3.810±0.127
B		0.020 (MAX)	0.508(MAX)
B1		0.055 (MAX)	1.397(MAX)
c		0.012 (MAX)	0.304 (MAX)
D		1.430 (MAX)	36.322 (MAX)
E		0.6 (TYP)	15.24 (TYP)
E1		0.52 (MAX)	13.208 (MAX)
e		0.100 (TYP)	2.540(TYP)
eB		0.625 (MAX)	15.87 (MAX)
L		0.180(MAX)	4.572(MAX)
S		0.06 (MAX)	1.524 (MAX)
Q1		0.08(MAX)	2.032(MAX)
Θ		15°(MAX)	15°(MAX)



28 pin 330 mil SOP Package Outline Dimension

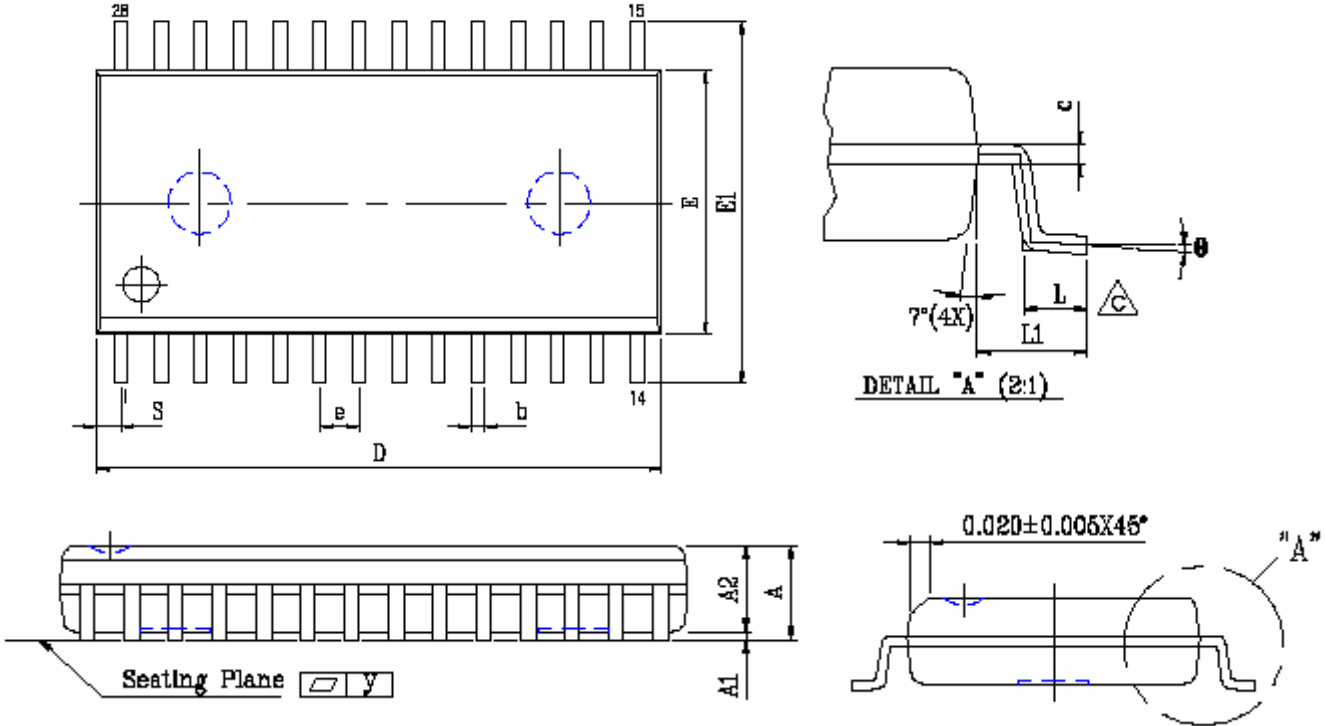

SYM.	UNIT	
	INCH(BASE)	MM(REF)
A	0.120 (MAX)	3.048 (MAX)
A1	0.002(MIN)	0.05(MIN)
A2	0.098±0.005	2.489±0.127
b	0.016 (TYP)	0.406(TYP)
c	0.010 (TYP)	0.254(TYP)
D	0.728 (MAX)	18.491 (MAX)
E	0.340 (MAX)	8.636 (MAX)
E1	0.465±0.012	11.811±0.305
e	0.050 (TYP)	1.270(TYP)
L	0.05 (MAX)	1.270 (MAX)
L1	0.067±0.008	1.702 ±0.203
S	0.047 (MAX)	1.194 (MAX)
y	0.003(MAX)	0.076(MAX)
Θ	0°~10°	0°~10°

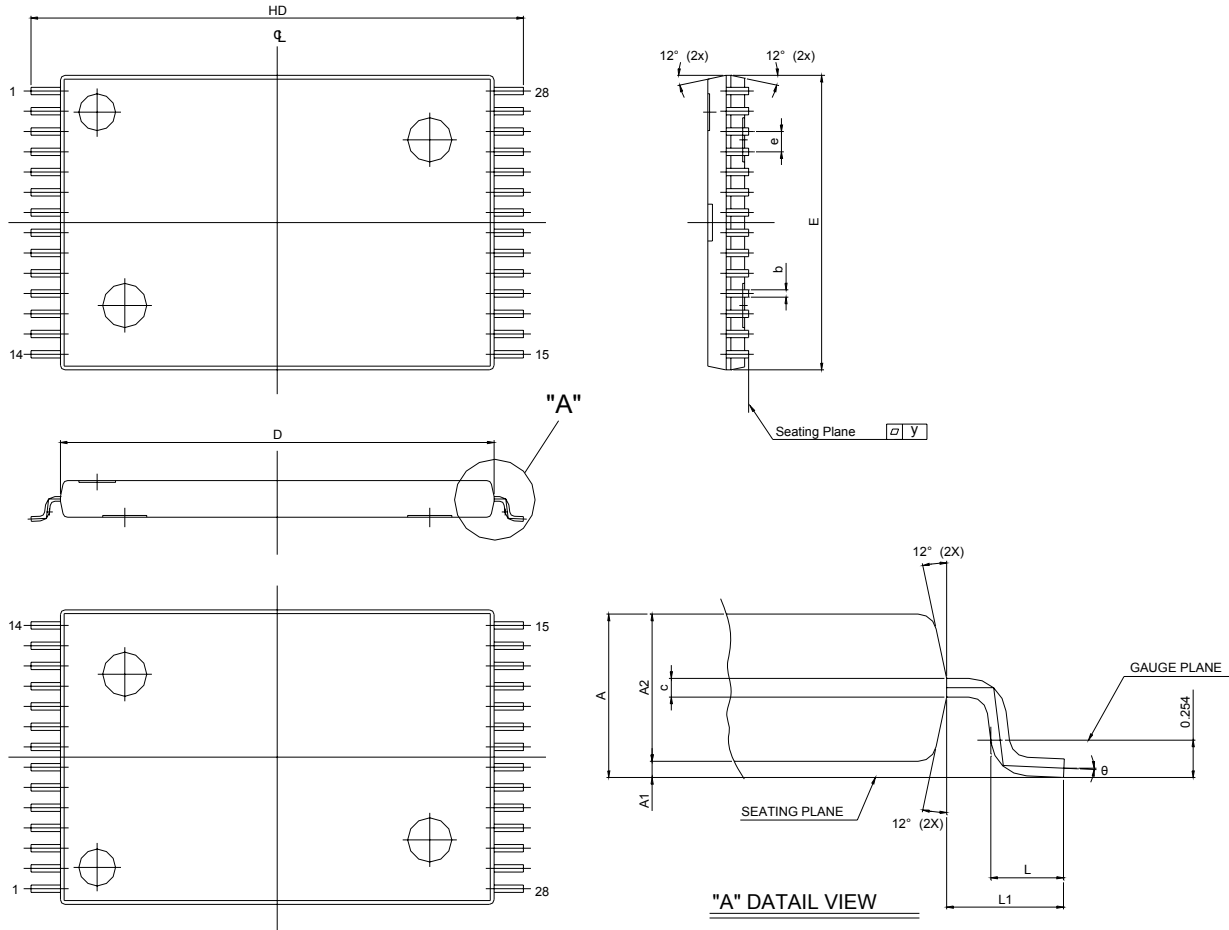
28 pin 8x13.4mm STSOP Package Outline Dimension

SYMBOLS	DIMENSIONS IN MILLIMETERS			DIMENSIONS IN INCHES		
	MIN	NOM	MAX	MIN	NOM	MAX
A	1.00	1.10	1.20	0.040	0.043	0.047
A1	0.05	-	0.15	0.002	-	0.006
A2	0.91	1.00	1.05	0.036	0.039	0.041
b	0.17	0.22	0.27	0.007	0.009	0.011
c	0.10	0.15	0.20	0.004	0.006	0.008
HD	13.20	13.40	13.60	0.520	0.528	0.535
D	11.70	11.80	11.90	0.461	0.465	0.469
E	7.90	8.00	8.10	0.311	0.315	0.319
e	-	0.55	-	-	0.0216	-
L	0.30	0.50	0.70	0.012	0.020	0.028
L1	0.675	-	-	0.027	-	-
Y	0.00	-	0.076	0.000	-	0.003
θ	0°	3°	5°	0°	3°	5°



28 pin 300 mil PDIP Package Outline Dimension

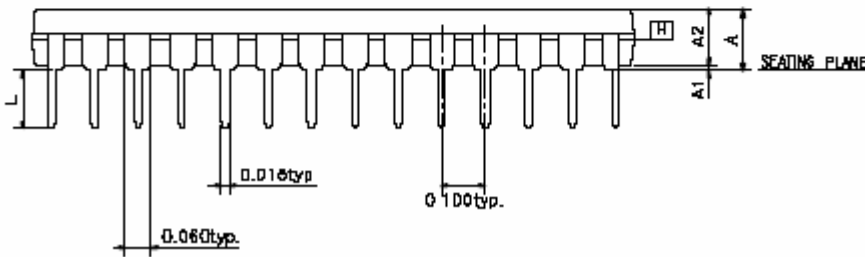
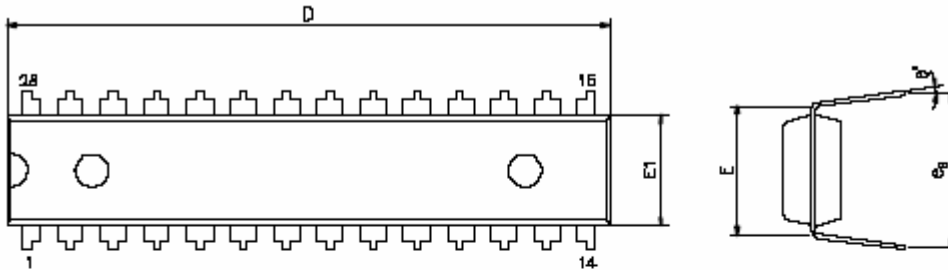

SYMBOLS	MIN.	NOR.	MAX.
A	—	—	0.210
A1	0.015	—	—
A2	0.125	0.130	0.135
D	1.385	1.390	1.400
E	0.310 BSC		
E1	0.283	0.288	0.293
L	0.115	0.130	0.150
eB	0.330	0.350	0.370
θ°	0	7	15

UNIT : INCH

NOTE:

1. JEDEC OUTLINE : MS-D15 AH



ORDERING INFORMATION

LY62256 V W - XX YY Z

Z : Temperature Range
Blank : (Commercial) 0°C ~ 70°C
E : (Extended) -20°C ~ 80°C
I : (Industrial) -40°C ~ 85°C

YY : Power Type
LL : Ultra Low Power

XX : Access Time(Speed)

W : Lead Information
N : Normal
L : Lead Free

V : Package Type
P : 28-pin 600 mil P-DIP
S : 28-pin 330 mil SOP
R : 28-pin 8 mm x 13.4 mm STSOP
D : 28-pin 300 mil P-DIP



Lyontek Inc.

LY62256

Rev. 2.5

32K X 8 BIT LOW POWER CMOS SRAM

THIS PAGE IS LEFT BLANK INTENTIONALLY.