

# Micro-Power Inverting DC/DC Controller

## FEATURES

- 2.4V to 7V Input Voltage Operation.
- Adjustable Output Voltage up to -40V.
- Low Quiescent Current at 80 $\mu$ A.
- Pulse Frequency Modulation Maintains High Efficiency (87%).
- 70KHz to 160KHz Switching Frequency.
- Power-Saving Shutdown Mode (0.7 $\mu$ A Typical).
- High Efficiency with Low Cost External PNP Bipolar Transistor.

## APPLICATIONS

- Negative LCD Contrast Bias for
  1. Notebook & Palmtop Computers.
  2. Pen-Based Data System.
  3. Portable Data Collection Terminals.
  4. Personal Digital Assistants.
- Negative Voltage Supply.

## DESCRIPTION

The AIC1652 is a high performance inverting DC/DC controller, designed to drive an external power switch to generate programmable negative voltages. In the particularly suitable LCD bias contrast application, efficiency of 87% can be achieved with low cost PNP bipolar transistor drivers. Output voltage can be scaled to -40V or greater by two external resistors. A pulse frequency modulation scheme is employed to maintain high efficiency conversion under wide input voltage range. Quiescent current is about 80 $\mu$ A and can be reduced to 0.7 $\mu$ A in shutdown mode. Switching frequency being around 70KHz to 160KHz range, small size switching components are ideal for battery powered portable equipments, like notebook and palmtop computers.

## TYPICAL APPLICATION CIRCUIT

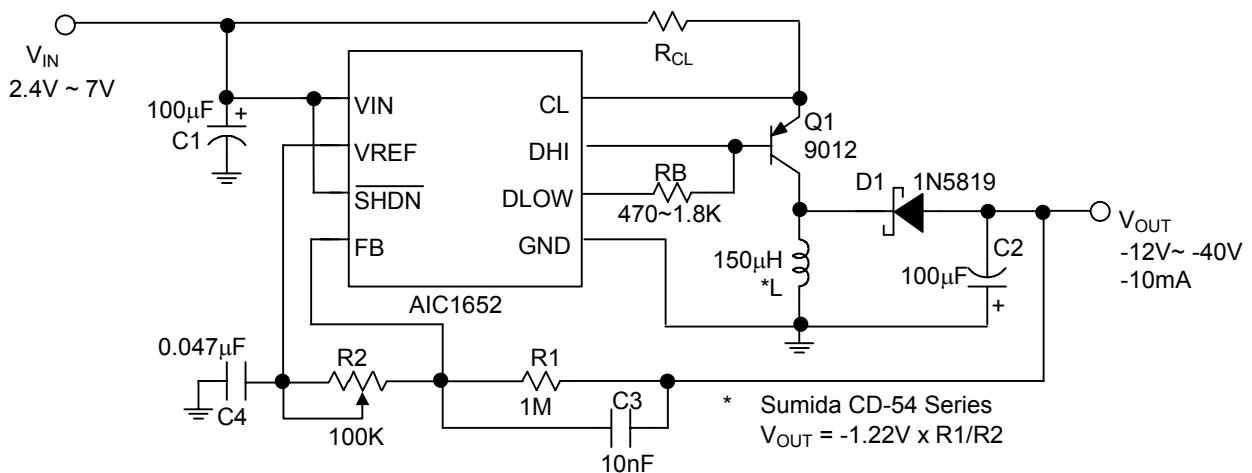

**Negative LCD Contrast Bias Power Supply**

**ORDERING INFORMATION**

AIC1652XXXX

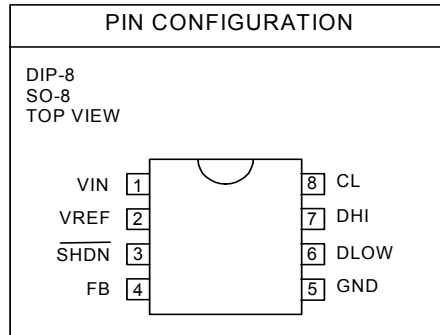
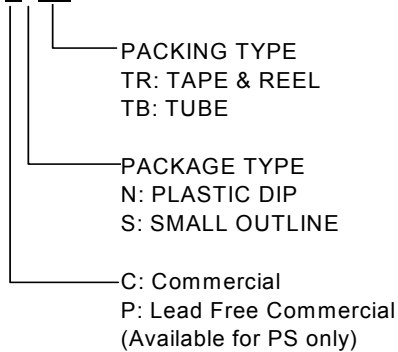

- EX: AIC1652CSTR  
 → in SO-8 Package & Tape & Reel Packing Type  
 (CN is not available in TR packing type.)  
 AIC1652PSTR  
 → in SO-8 Lead Free Package & Tape & Reel Packing Type

**ABSOLUTE MAXIMUM RATINGS**

Supply Voltage .....	7V
$\overline{\text{SHDN}}$ Voltage .....	7V
Operation Temperature Range .....	0°C~70°C
Storage Temperature Range .....	-65°C~ 150°C

**TEST CIRCUIT**

Refer to Typical Application Circuit.

**■ ELECTRICAL CHARACTERISTICS** ( $V_{IN}=5V$ ,  $T_a=25^{\circ}C$ , unless otherwise specified.)

PARAMETER	TEST CONDITIONS	MIN.	TYP.	MAX.	UNIT
Input Voltage		2.4		7	V
Switch Off Current	$V_{FB}=-50mV$		80	150	$\mu A$
$V_{REF}$ Voltage	$I_{SOURCE} = 250\mu A$	1.16	1.22	1.28	V
$V_{REF}$ Source Current		250			$\mu A$
DLOW "ON Resistance"			5		$\Omega$
DHI "ON Resistance"			7		$\Omega$
CL Threshold			70		mV
Shutdown Threshold		0.8	1.5	2.4	V
Shutdown Mode Current	$V_{SHDN} = 0V$		0.7	2	$\mu A$

**TYPICAL PERFORMANCE CHARACTERISTICS**

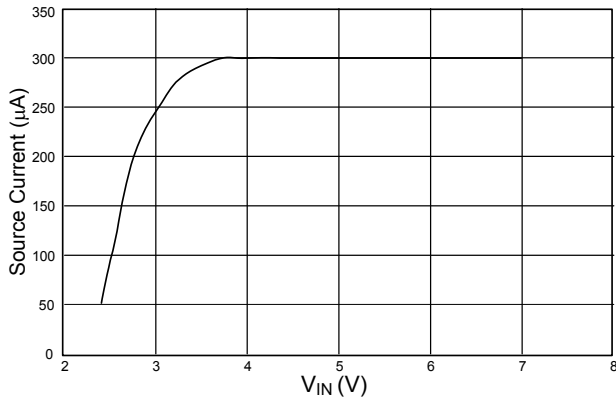

Fig. 1  $V_{REF}$  Source Current vs.  $V_{IN}$

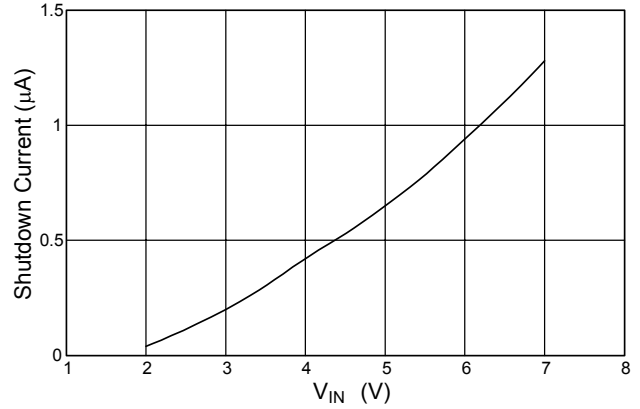

Fig. 2 Shutdown Current vs.  $V_{IN}$

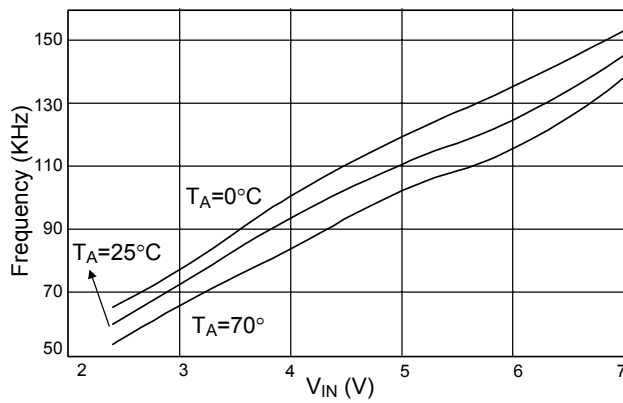

Fig. 3 Frequency vs.  $V_{IN}$  Voltage

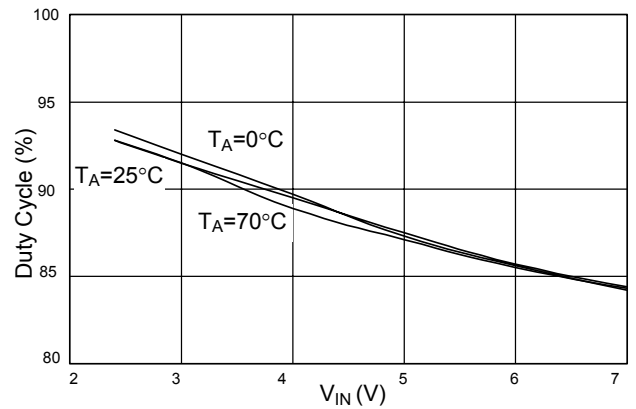

Fig. 4 Duty Cycle vs.  $V_{IN}$  Voltage

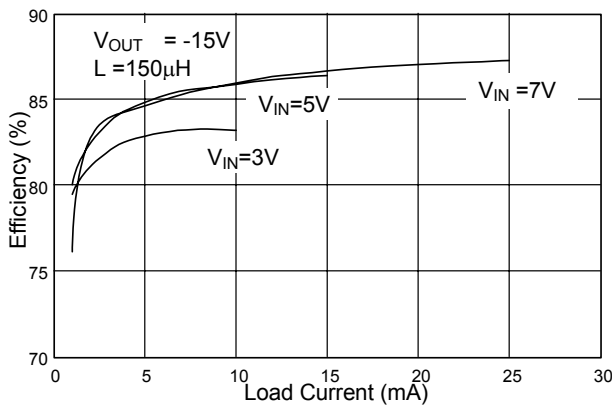

Fig. 5 Efficiency vs. Load Current

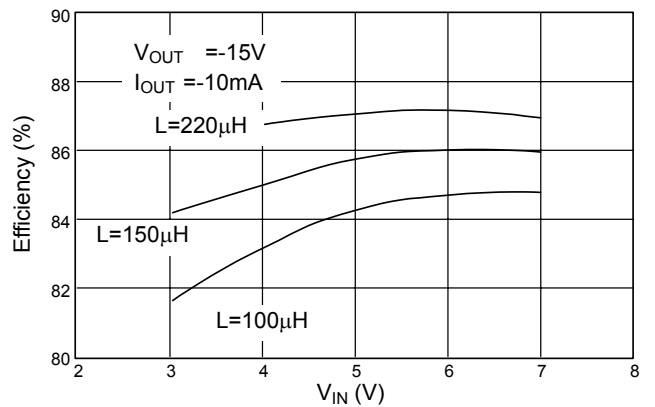

Fig. 6 Efficiency vs.  $V_{IN}$

**TYPICAL PERFORMANCE CHARACTERISTICS (Continued)**

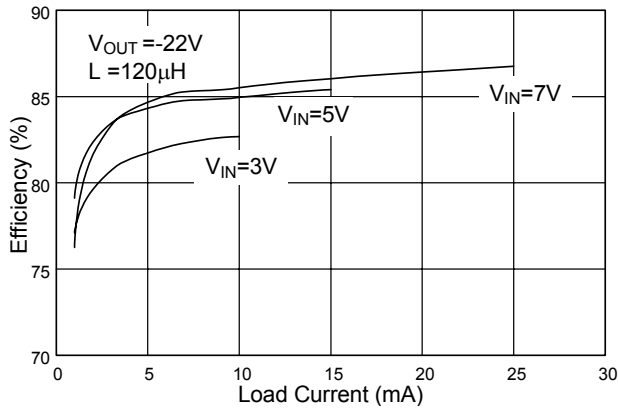

Fig. 7 Efficiency vs. Load Current

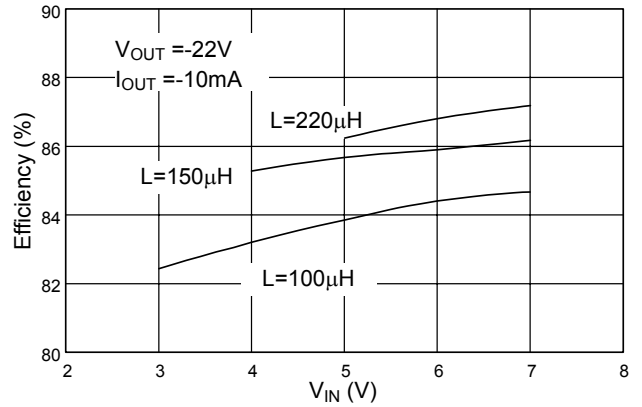

Fig. 8 Efficiency vs. VIN

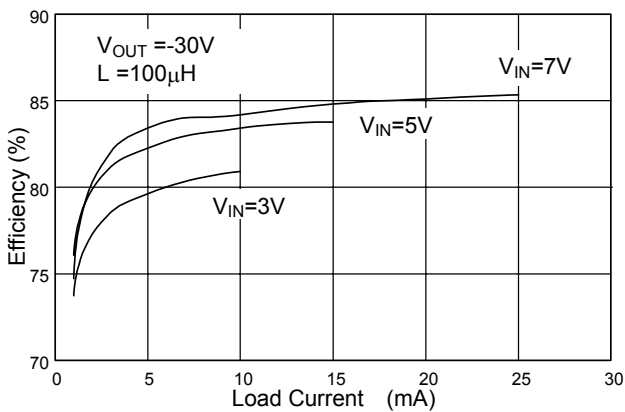

Fig. 9 Efficiency vs. Load Current

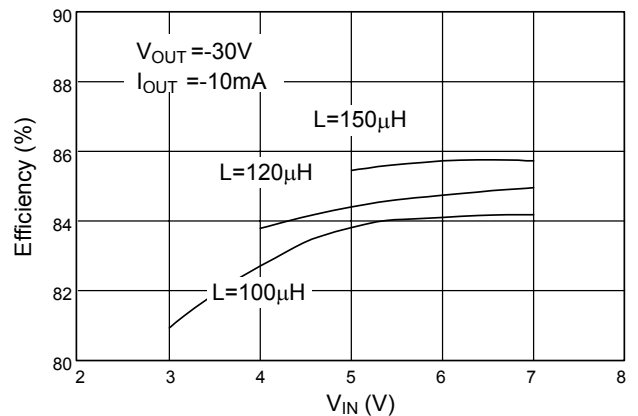
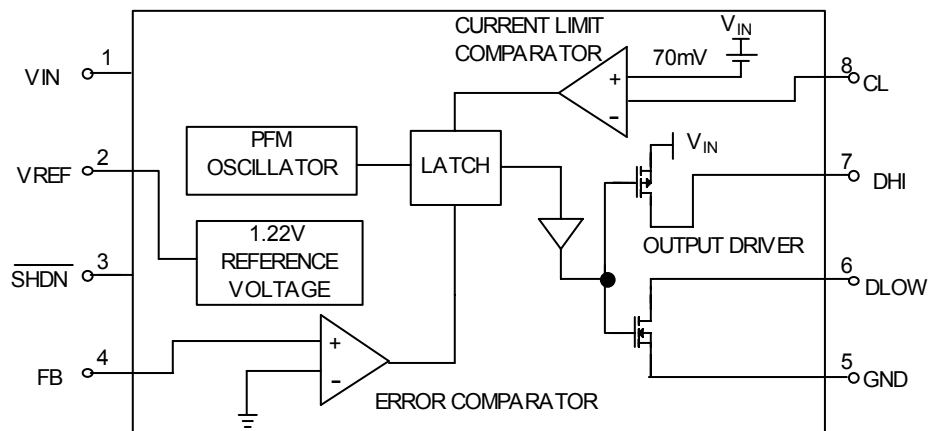

Fig. 10 Efficiency vs. VIN

**BLOCK DIAGRAM**



## PIN DESCRIPTIONS

PIN 1: VIN - Input supply voltage (2.4V~7V)

PIN 2: VREF - Reference output (1.22V). Bypass with a 0.047μF capacitor to GND. Sourcing capability is guaranteed to be greater than 250μA.

PIN 3:  $\overline{\text{SHDN}}$  - Logic input to shutdown the chip.  
 >1.5V = normal operation,  
 GND = shutdown  
 In shutdown mode DLOW and DHI pins are at high level.

PIN 4: FB - Feedback signal input to sense ground. Connecting a resistor R1 to V<sub>OUT</sub> and a resistor R2 to V<sub>REF</sub> pin yields the output voltage:

$$V_{\text{OUT}} = -(R1/R2) \times V_{\text{REF}}$$

PIN 5: GND - Power ground.

PIN 6: DLOW - Driver sinking output. Connected to DHI when using an external P-channel MOSFET. When using an external PNP bipolar transistor, connect a resistor RB from this pin to DHI. RB value depends on V<sub>IN</sub>, inductor and PNP bipolar transistor. By adjusting the RB value, efficiency can be optimized.

PIN 7: DHI - Driver sourcing output. Connect to gate of the external P-channel MOSFET or base of the PNP bipolar transistor.

PIN 8: CL - Current-limit input. This pin clamps the switch peak current to prevent over-current damage to the external switch.

## APPLICATION INFORMATIONS

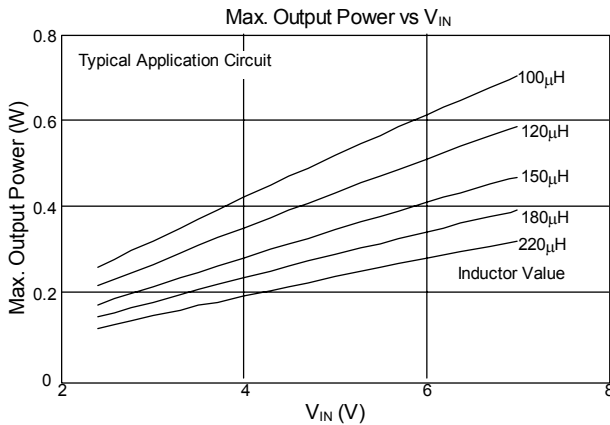

The typical application circuit generates an adjustable negative voltage for contrast bias of LCD displays. Efficiency and output power can be optimized by using appropriate inductor and switch. The following formulas provide a guideline for determining the optimal component values:

$$L = (11.1 - 0.15 \times V_{\text{IN}}) \times \frac{V_{\text{IN}}}{|I_{\text{OUT}}| \times |V_{\text{OUT}}|}$$

$$\text{PNP} : |V_{\text{CEO}}| > V_{\text{IN}} + |V_{\text{OUT}}|$$

$$|I_{\text{C,MAX}}| \geq 200 \times \frac{|I_{\text{OUT}}|}{V_{\text{IN}}}$$

$$|V_{\text{CE}}| < 0.4\text{V at } I_{\text{C}} = 200 \times \frac{I_{\text{OUT}}}{V_{\text{IN}}}$$

$$\text{and } \beta = 10$$

$$R_{\text{B}} \cong 3 \times L \times (V_{\text{IN}} - 0.8)$$

where, V<sub>IN</sub>(V), V<sub>OUT</sub>(V), I<sub>OUT</sub>(A), L(μH), R<sub>B</sub>(Ω)

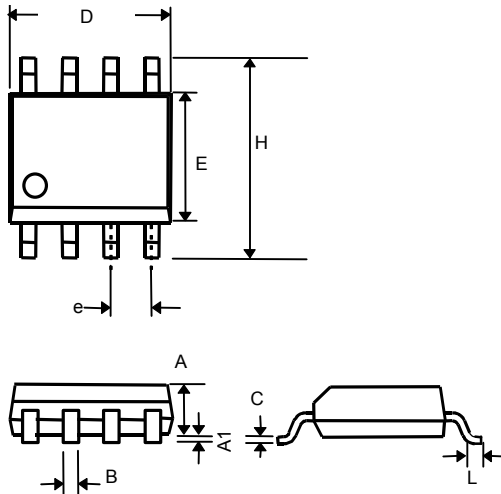
**PHYSICAL DIMENSIONS (unit: mm)**
**8 LEAD PLASTIC SO (CS) (PS)**

SYMBOL	MIN	MAX
A	1.35	1.75
A1	0.10	0.25
B	0.33	0.51
C	0.19	0.25
D	4.80	5.00
E	3.80	4.00
e	1.27(TYP)	
H	5.80	6.20
L	0.40	1.27

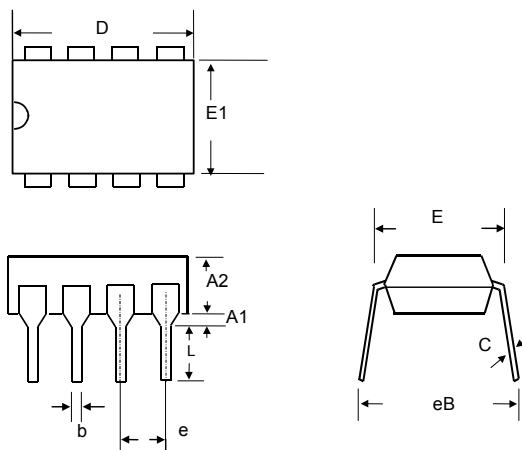
**8 LEAD PLASTIC DIP (CN)**

SYMBOL	MIN	MAX
A1	0.381	—
A2	2.92	4.96
b	0.35	0.56
C	0.20	0.36
D	9.01	10.16
E	7.62	8.26
E1	6.09	7.12
e	2.54 (TYP)	
eB	—	10.92
L	2.92	3.81

**Note:**

Information provided by AIC is believed to be accurate and reliable. However, we cannot assume responsibility for use of any circuitry other than circuitry entirely embodied in an AIC product; nor for any infringement of patents or other rights of third parties that may result from its use. We reserve the right to change the circuitry and specifications without notice.

Life Support Policy: AIC does not authorize any AIC product for use in life support devices and/or systems. Life support devices or systems are devices or systems which, (i) are intended for surgical implant into the body or (ii) support or sustain life, and whose failure to perform, when properly used in accordance with instructions for use provided in the labeling, can be reasonably expected to result in a significant injury to the user.